



**VAC MODULAR FULLY AUTOMATIC P.S. LABELER**  
Suitable for cylindrical product labeling. No change-parts needed.

**Features:**

- Modular Design
- Can be fitted with up to 3 Labeling Heads
- Label placement of +/- 1mm
- Tapered Bottle capable
- No tooling/change-parts
- Fast package change-over
- Operator interface/touch-screen
- Designed to fit in new or existing line
- Orientation available
- Output rate of up to 300bpm
- Ideal for mobile lines

**Specifications:**

PLC:	As specified by client
Power:	220v /Single Phase/ 20amp
Web Speed:	0-60 Linear Meters
Label Drive:	AC Servo closed loop
Positioning:	AC Servo closed loop
Execution:	Left or Right
Frame:	Stainless/Aluminum
Label size:	Vertical axis 160mm Horizontal axis 220mm



### OPERATOR INTERFACE/TOUCH-SCREEN

- Link to PLC
- Available in Different languages
- Located on a Swivel arm for easy access
- Analogue reference to control all AC motors
- Mitsubishi standard or as specified
- Change settings “on-the-fly”

### FEEDSCREW ASSEMBLY

- Positive product separation
- Controlled through Operator Interface/Touch-screen
- One feed-screw will fit wide range of container sizes
- Quick change system

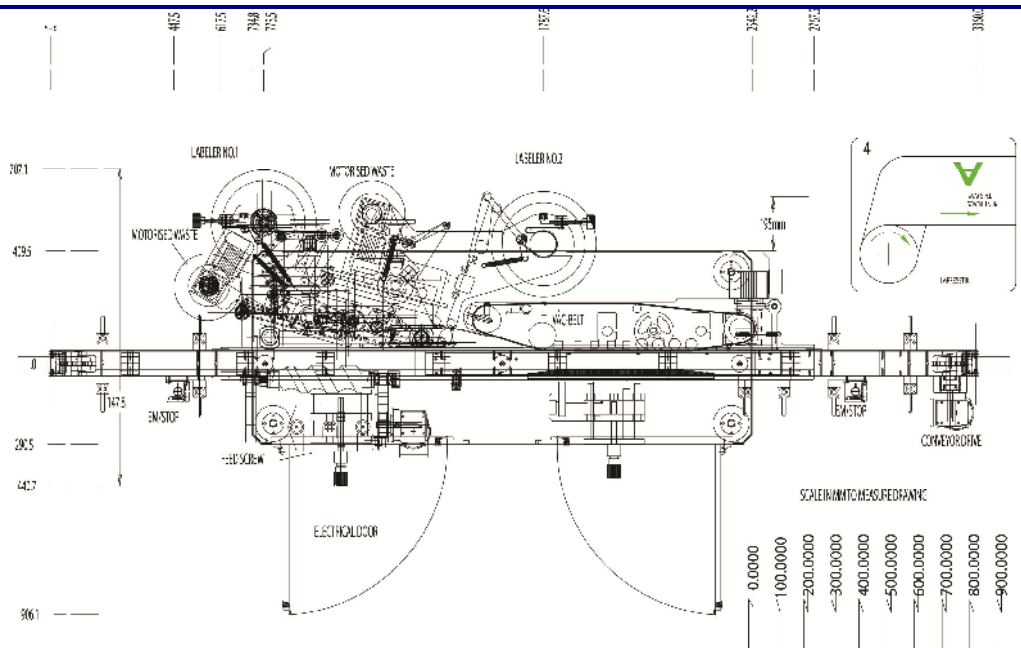
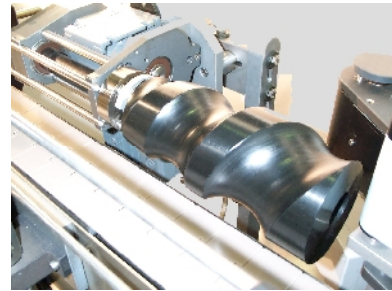

Left execution layout shown. Machine available in right execution also. This machine layout is shown with optional conveyor drive and conveyor extensions. Customized versions of this machine can be manufactured to specification.



[www.impresstiklabelers.com](http://www.impresstiklabelers.com)

More than 200 Impresstik labelers have been installed into the North American Wine Industry with 50+ installed into mobile bottling lines. All machines are manufactured to the customer's specifications

[andy@impresstiklabelers.com](mailto:andy@impresstiklabelers.com)